

Doorslagbeveiligde machinevoeten DNV gecertificeerd

Art.Code	L (mm)	Ls (mm)	K (mm)	D (mm)	H (mm)	B (mm)	M (mm)	d (mm)	Shore A
6015840S	170	140	125,5	162	58	170	M20i	14,5	40°
6015850S	170	140	125,5	162	58	170	M20i	14,5	50°
6015860S	170	140	125,5	162	58	170	M20i	14,5	60°
6015870S	170	140	125,5	162	58	170	M20i	14,5	70°

Indien gewenst is de machinevoet leverbaar met hoogteverstelling

- L = lengte
- Ls = hartafstand bevestigingsgaten
- K = diameter kap
- D = diameter
- H = hoogte
- B = breedte
- M = schroefdraad
- d = boring
- Shore A = hardheid

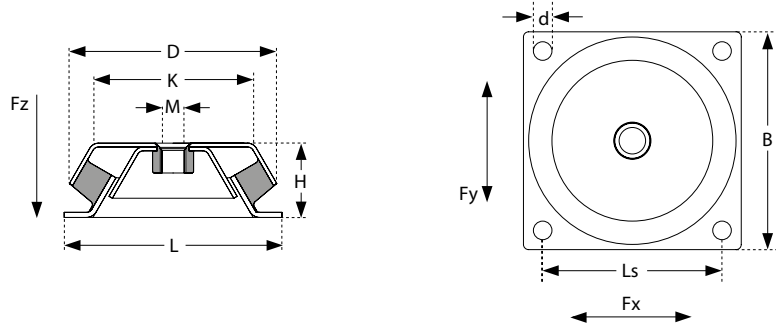

Belasting Fz

